

## Annual Power Engineering Exchange (APEX)

# Remote Signal Conditioning

USING PROGRAMMABLE CONTROLLERS TO IMPROVE SIGNAL QUALITY

**EVA WENHAM**  
POWER SYSTEMS ENGINEER



DATE: 6 OCTOBER

**EEA.CO.NZ**



*Thank you to our sponsors for their support.*

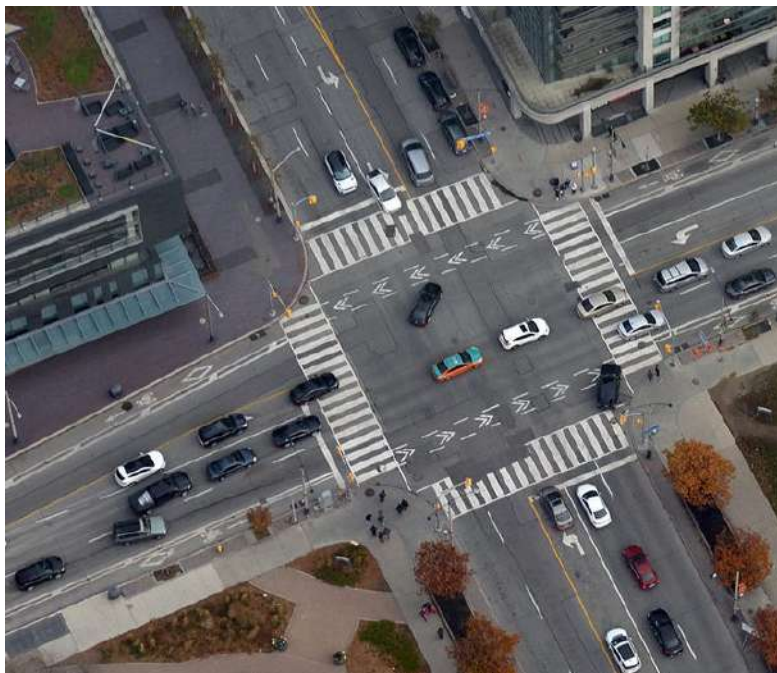

# INTRODUCTION

## 1. HAYWARDS SUBSTATION

## 2. THE PROBLEM

## 3. DISCONNECTOR AUXILIARY CONTACTS

## 4. BISTABLE RELAYS

## 5. THE WORST-CASE SCENARIO

## 6. THE SOLUTION: SIGNAL CONDITIONING

## 7. WHAT MAKES THIS SOLUTION INNOVATIVE?

# 1. HAYWARDS SUBSTATION

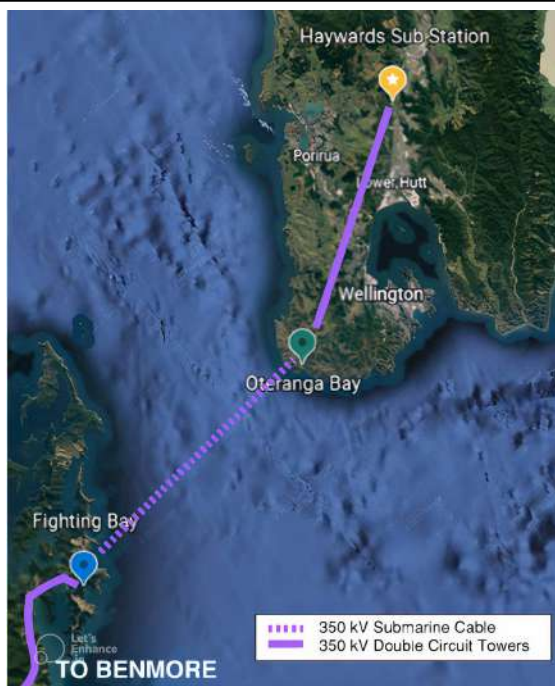

- 19 220 kV Bays
- Four main 220 kV buses (A, B, C & D) with an overall check zone
- Benmore transmits up to 1,200 MW of power to / from Haywards, it travels there through a variation of undersea cables and overhead 350 kV lines.
- Two overhead lines run into Haywards, one feeding into Pole 2 which connects to buses A or B and one feeding into Pole 3 which connects into buses B or C.
- From the 220 kV busbars power connects into the lower NI 220 kV grid supplies local load via 220/110 kV transformers



## 2. THE PROBLEM

### THE PROBLEM WITH THE EXISTING SCHEME:

- For each bus selection bus disconnector there are three individual sets of contacts that need to be considered
- The three phases of each DIS are not mechanically linked, so can be out of synch
- Due to these synch issues, the BZ selection bistable relays can receive both open and close signals across both SET and RESET coils



EWO

## 3. DISCONNECTOR AUXILIARY CONTACTS

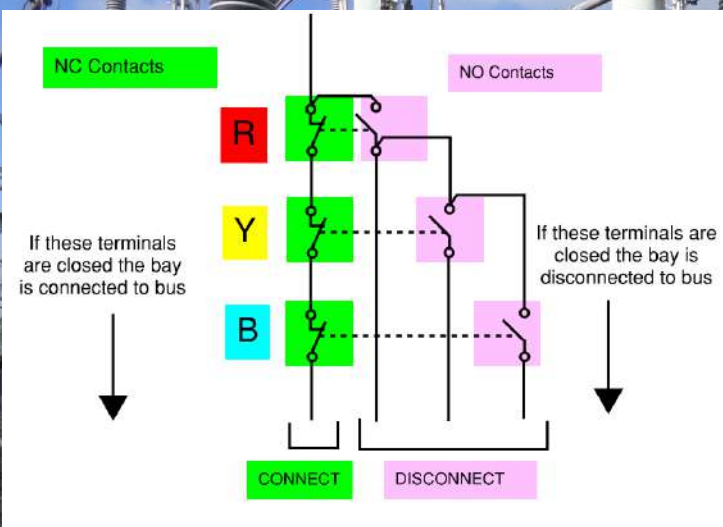

- One contact per phase
- NC = DIS open status
- NO = DIS closed status
- When the disconnector closes, normally open (NO) contacts close, and normally closed (NC) contacts open



## Slide 6

---

**EW0** Maybe make SLD more visible  
Eva Wenham, 2022-09-22T00:20:34.529

### 3. DISCONNECTOR AUXILIARY CONTACTS

■ CLOSED

□ OPEN

■ INTERMEDIATE POSITION

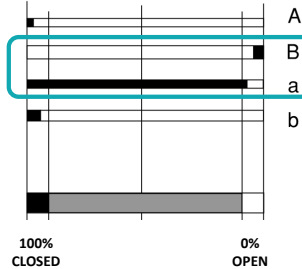

#### Relationship with Primary Disconnector Contacts

- 1a) Between 0-4%: NC Contact Closed
- 1b) Between 4-100%: NC Contact Opened
- 2a) Between 0-7%: NO Contact Opened
- 2b) Between 7-100%: NO Contact Closed

All NC contacts closed: Signals for bay connected to bus  
Any NO contact closed: Signals for bay to disconnect from bus

eea Electricity Engineers' Association



### 4. BISTABLE RELAYS

#### VOLTAGE ON THE SET TERMINAL:

- Happens when ONE DIS NO Contact is shut
- When the bay is connected to the bus
- Closes selection relay output contacts
- Cannot be triggered again until the RESET terminal is triggered

#### VOLTAGE ON THE RESET TERMINAL:

- Happens when ALL NC Contacts are shut
- When the bay is disconnected from the bus
- Opens selection relay output contacts
- Cannot be triggered again until the SET terminal is triggered

eea Electricity Engineers' Association



## 5. THE WORST-CASE SCENARIO

- When the disconnector position is between 4-7% both contacts should be open on ALL disconnector phases
- Transpower requires a 20% margin between contact opening and closing.
- This means that both terminals of the bistable relay can possibly have a voltage on them
- This can cause the SET and RESET terminals to be triggered simultaneously
- This causes the output contacts to rapidly open and shut (chatter), possibly damaging the relay

Between 4-7%: Both NO & NC Contacts should be open but there is a chance that they are both closed due to small error margin.

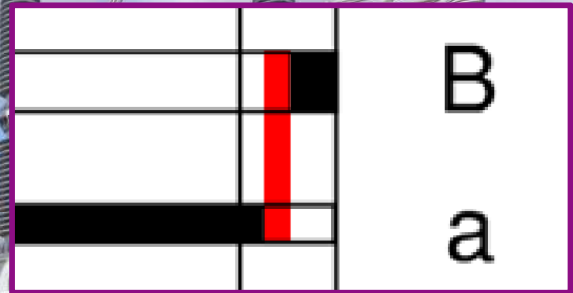

## 6. THE SOLUTION: SIGNAL CONDITIONING

Output contacts from disconnector auxiliary switches sent to Bay Controllers in bay ODJBs

1. Inputs checked to see that only one status has been sent for each contact in that 20ms interval, e.g. RØ contact is OPEN and NOT CLOSED
2. Checks all phases to see if they're in the same state
3. Sends the conditioned signal to the busbar selection bistable relay

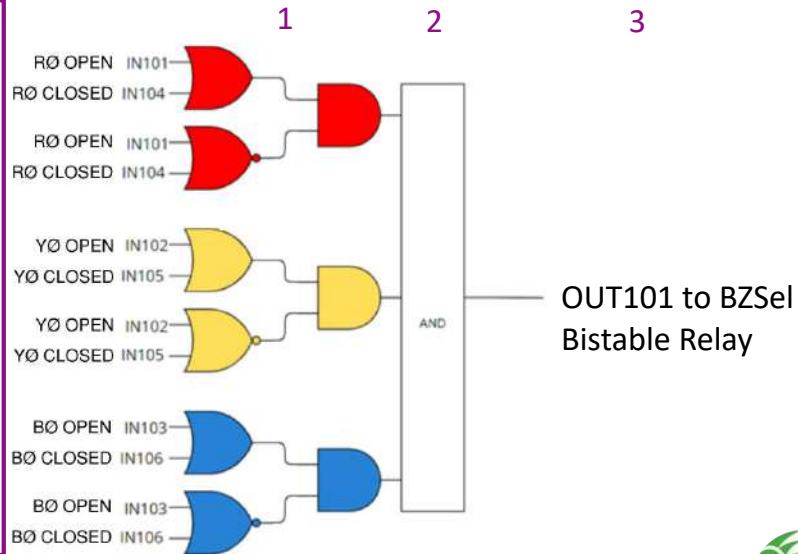

## 6. THE SOLUTION: SIGNAL CONDITIONING

### Solution Option A: Panel Mounted BayConts

Advantages:

- No remote BZ devices

Disadvantages

- Higher cost
- More BZ panels required
- Significant AC and DC Wiring required between panels
- BZ Sel(IO) panel and GOOSE messaging needed to connect switchyard B & C IO mounted in Pole 2 & 3 Relay Room to BZ Panels in Relay Room A

### Solution Option B: ODJB Mounted BayConts

Advantages:

- Least number of BZ selection panels required in relay room
- Less switchyard cabling
- ODJB Mounted SEL2440 share SCADA and BZSel functionality reducing the overall number of IEDs (Intelligent Electronic Devices, e.g. a relay)

Disadvantages

- GOOSE Messaging required
- HVDC Bays will need to be retrofitted.



Electricity Engineers' Association



## 7. WHAT MAKES THIS SOLUTION INNOVATIVE?

USES EXISTING EQUIPMENT  
IN AN ENTIRELY NEW WAY

REDUCED WIRING BETWEEN  
PANELS

CAN DO SCADA AND BZ  
SELECTION FUNCTIONALITY

INPUTS AND OUTPUTS CAN  
BE MONITORED

REDUCED COPPER CABLING

PRACTICAL FOR VERY LARGE  
SWITCHYARDS

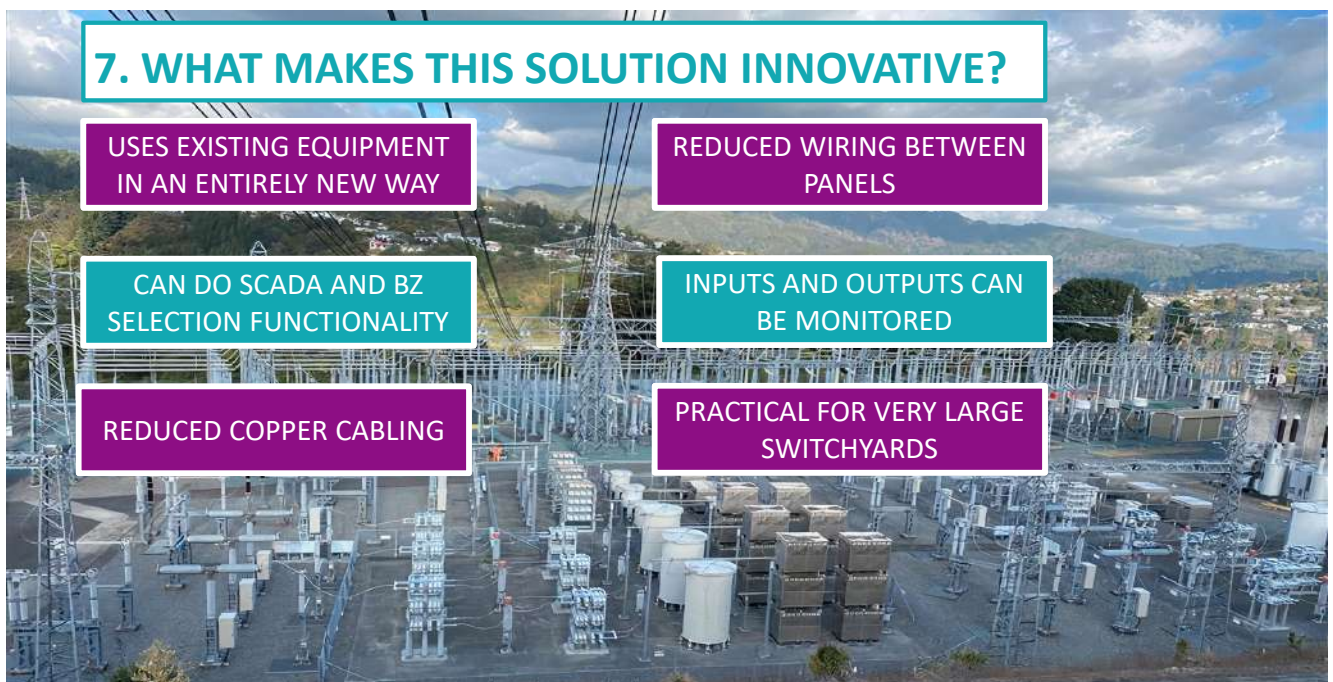

Electricity Engineers' Association



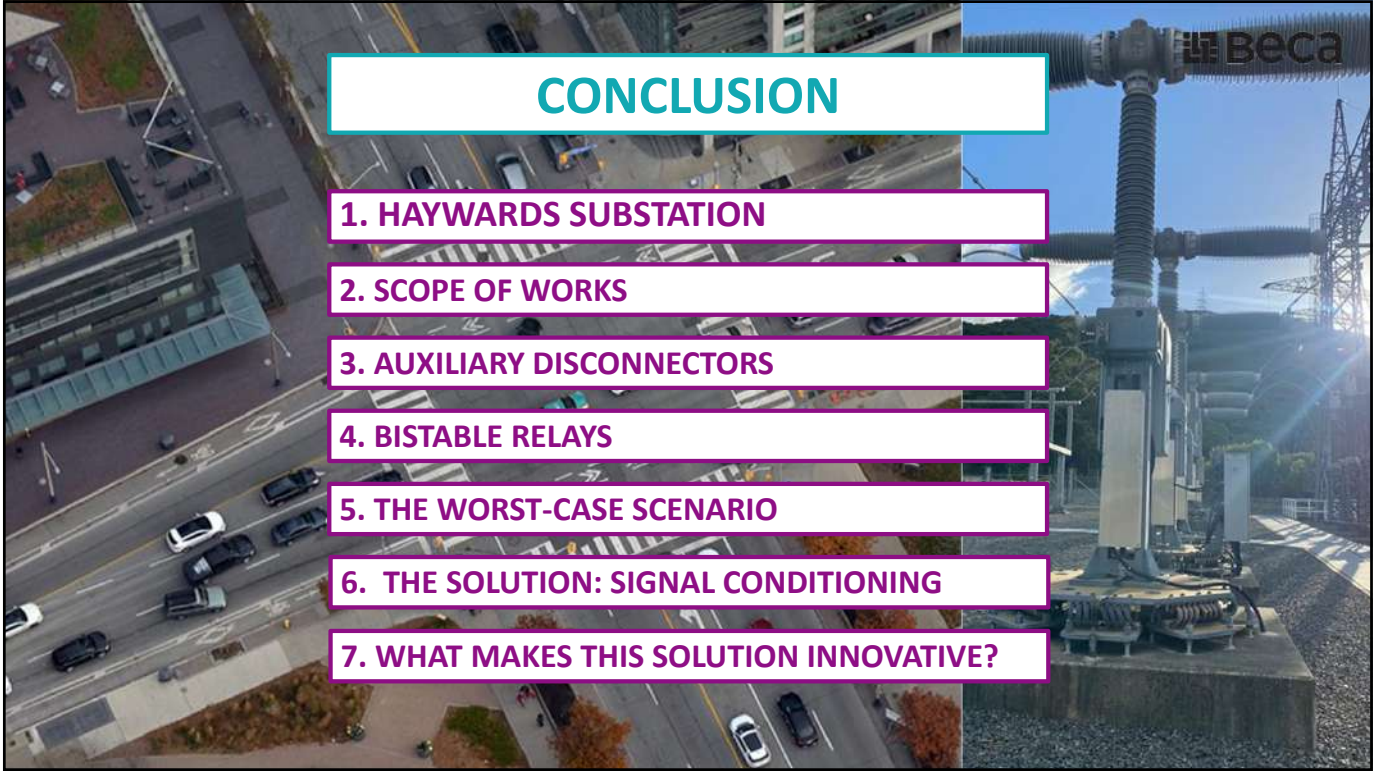

# CONCLUSION

1. HAYWARDS SUBSTATION

2. SCOPE OF WORKS

3. AUXILIARY DISCONNECTORS

4. BISTABLE RELAYS

5. THE WORST-CASE SCENARIO

6. THE SOLUTION: SIGNAL CONDITIONING

7. WHAT MAKES THIS SOLUTION INNOVATIVE?