

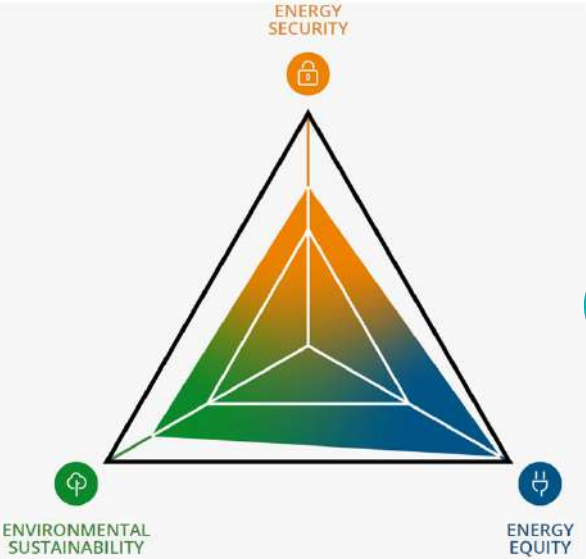

CONTENTS





GRID CHALLENGES

BECA

Image credit to World Energy Council





 Beca

INTERMITTENT GENERATION

 Home News Radio Podcasts & Series Topics Te Ao Māori Pacific IndoNZ 中文

New Zealand World Politics Pacific Te Ao Māori Sport Business Country Local Democracy Reporting

NEW ZEALAND / INFRASTRUCTURE

Cyclone Gabrielle electricity outages beyond Transpower's control - Commerce Commission

7:40 pm on 27 September 2023

Share this     

 **Rayssa Almeida**, Reporter
 @rayssalmelmeida  rayssa.almeida@rnz.co.nz

Otago Daily Times

News Sport Life & Style Entertainment Business Regions

Sunday, 15 October 2023

Thousands without power in Canterbury after strong winds

UNPLANNED OUTAGES & EMERGENCY EVENTS





A runback scheme reduces the flow of electricity in a given network element in a controlled way, in response to a specific event.

- Australian Energy Market Operator

RUNBACK SCHEME FUNCTIONALITY



Detect high power flows through a given network element(s)

DISPATCH
MINUTES/HOURS



RUNBACK
SECONDS



NETWORK ELEMENTS TO PROTECT

OVERLOADING = HEATING

HEATING =



- 1 Aging of plant
- 2 Failure of plant
- 3 Sagging of lines
- 4 Less efficient operation

 **BECA**



 **BECA**

GENERATION TYPES FOR RUNBACK



WHAT DID WE DO BEFORE?

- The grid has relied on being rated to operate with N-1 capacity.
- Any new generation connected in would be limited to N-1 capacity or require upgrades to network.

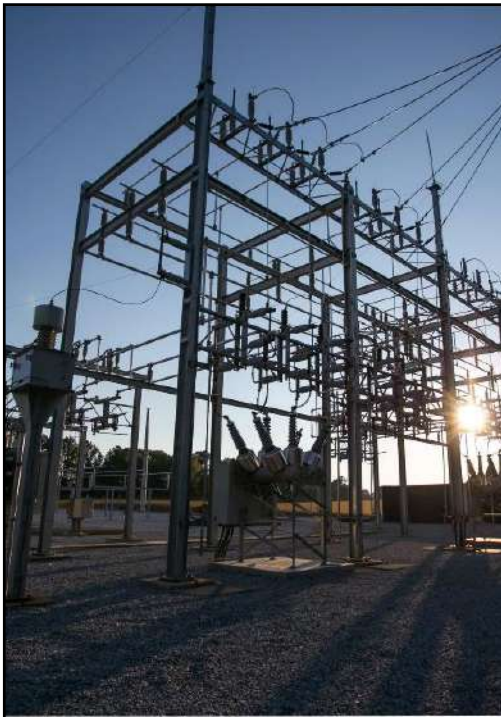

WHY RUNBACK SCHEMES NOW?

- New generation that is being installed is intermittent, and easily controllable.
- Fast, reliable communications mean that signals can be acted upon quickly.



CASE STUDY



CASE STUDY: RURAL AUSNET TERMINAL STATION

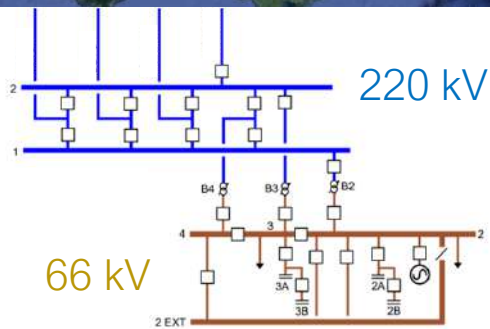

- 3x 220/66 kV Transformers
- Main supply for > 68000 customers
- Significant embedded generation (> 415 MW)

Courtesy of AusNet Services

PROJECTS AT/NEAR STATION:

- Terminal station redevelopment
 - 2 x transformer replacement
 - Various primary plant replacement
 - Demolition and redevelopment of switchroom
- Distribution network connection of 2 x solar farms nearby

ROLE OF BECA:

- Design services for:
 - Terminal station redevelopment
 - AusNet side of solar farm connections including a runback scheme



Courtesy of AusNet Services

RURAL TERMINAL STATION

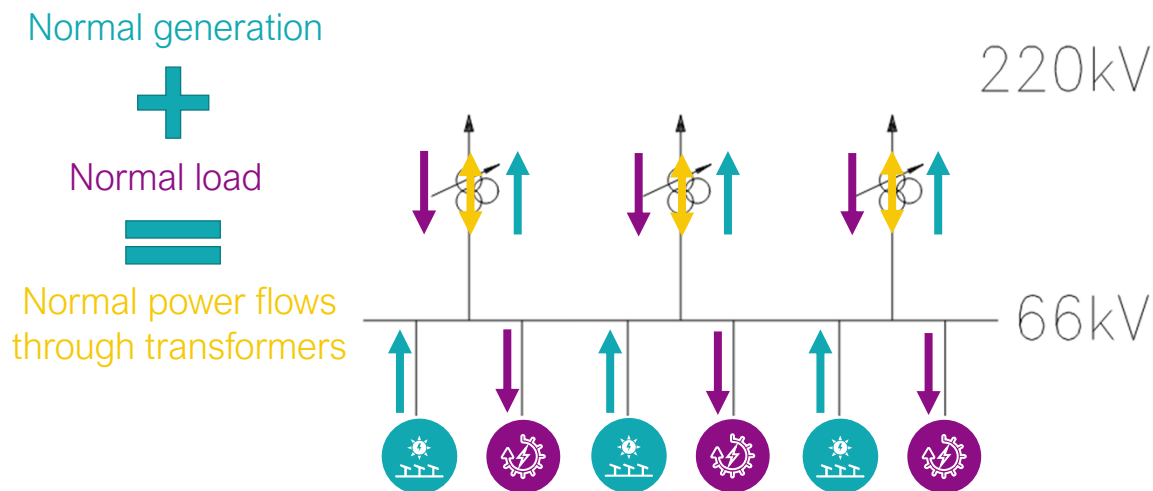

Courtesy of AusNet Services

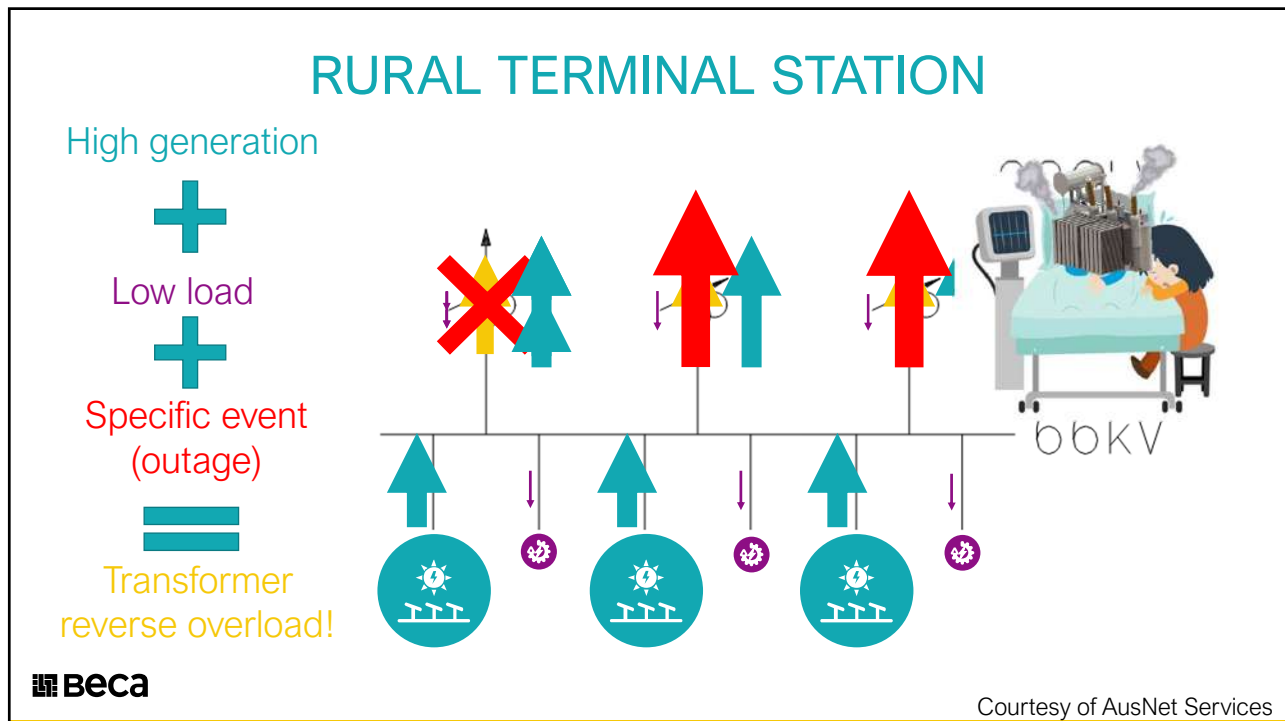
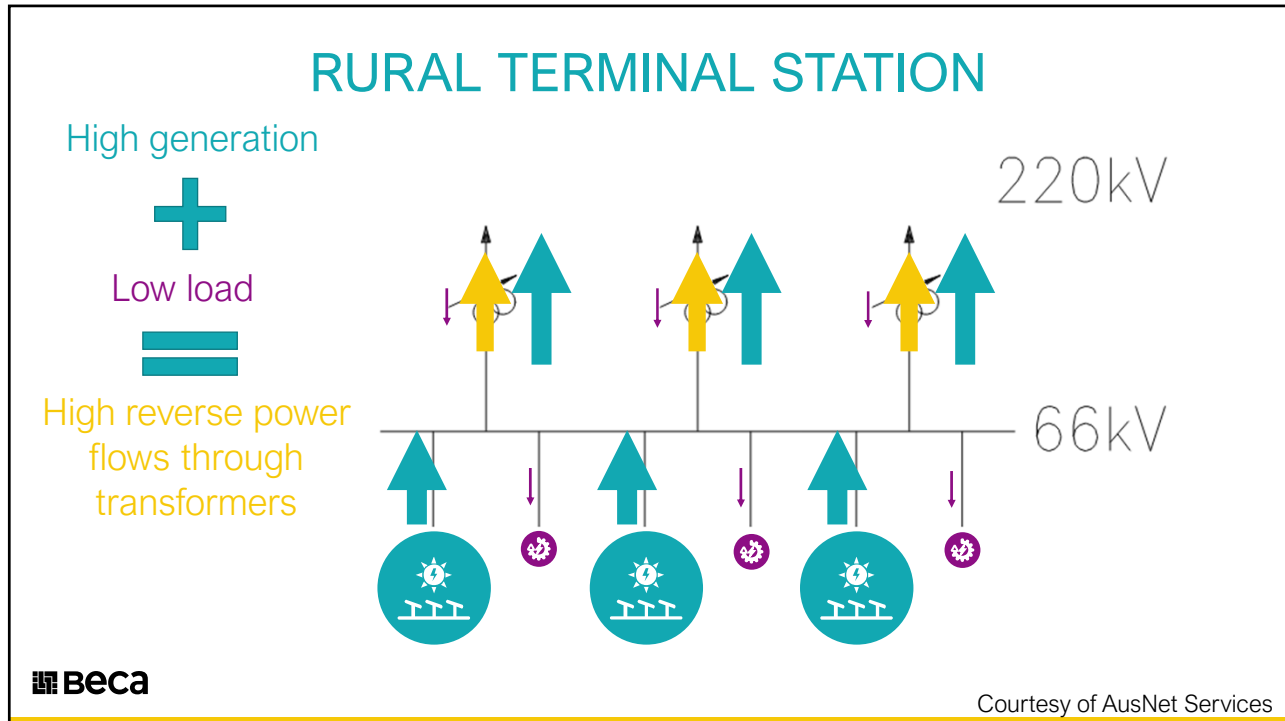

PRE-CONTINGENCY OPTIONS:

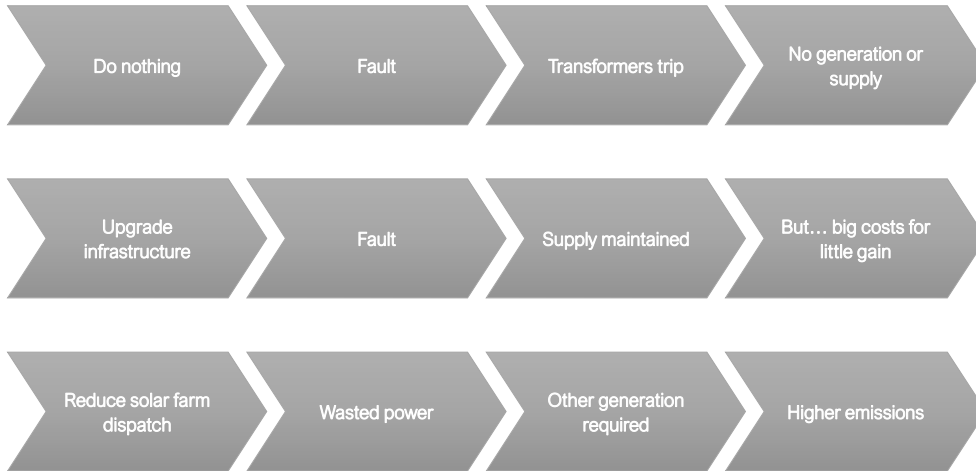

RURAL TERMINAL STATION

High generation



Low load



Specific event (outage)



Runback scheme

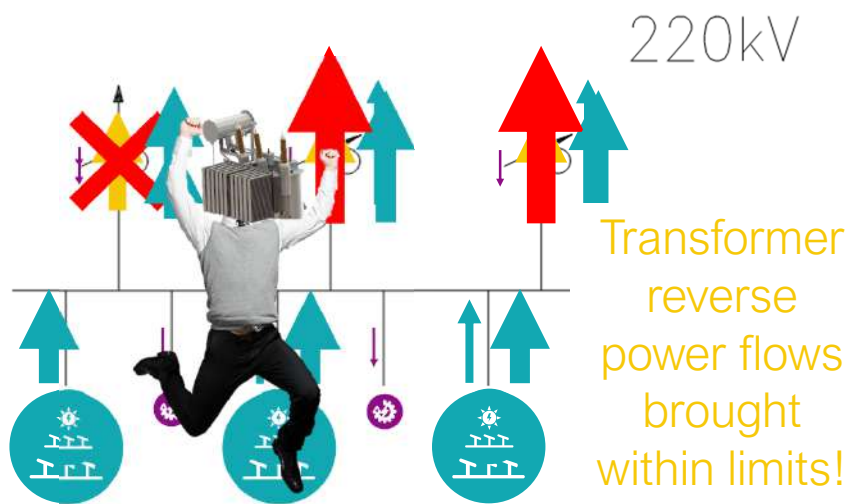

Courtesy of AusNet Services

PRE-CONTINGENCY WITH RUNBACK

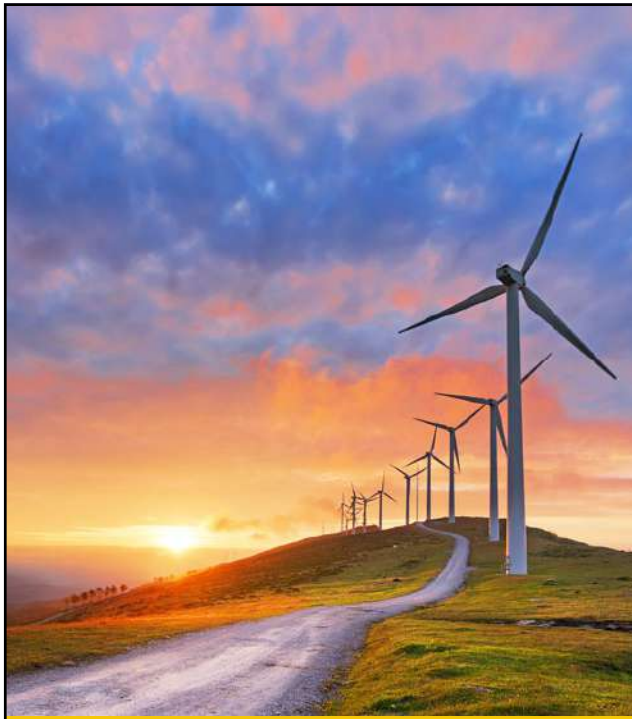
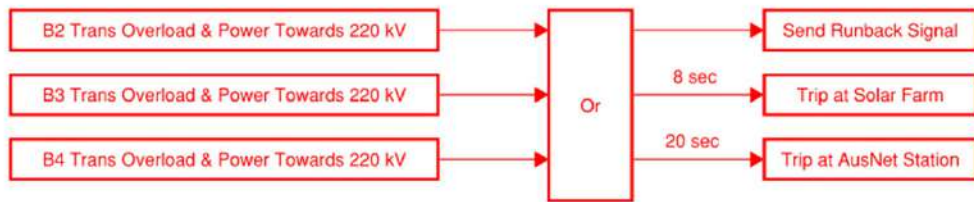
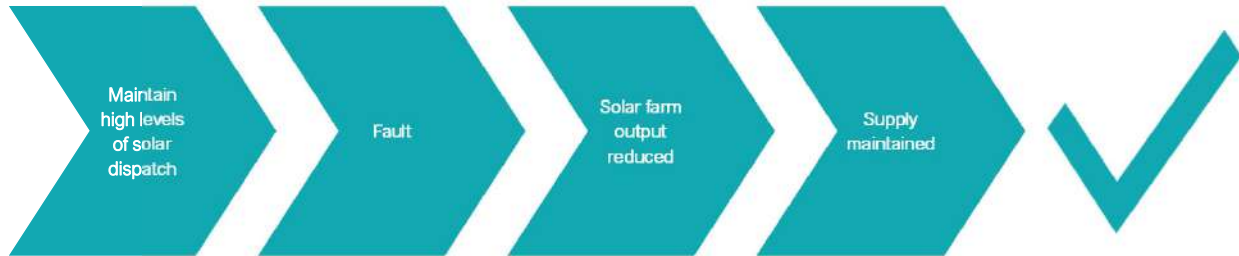

INTO THE FUTURE

CHALLENGES

- Wasting power -> BESS?
- Increased operational complexity
 - Potential for misoperation
- Runback schemes vs equipment upgrades

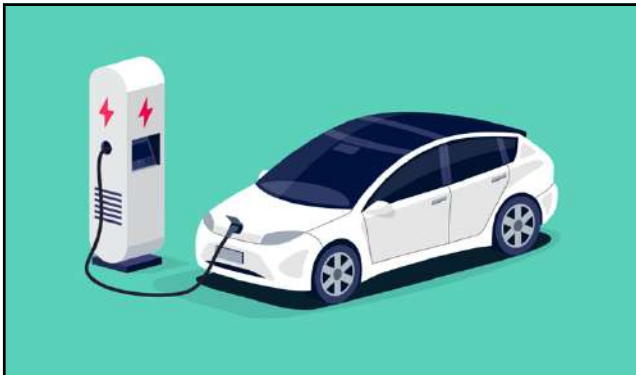

INTO THE FUTURE

- Integration with demand response?
- Smart runback control?
- Runback across multiple generators?

New Connection Enquiries  **TRANSPOWER**

Number of enquiries
366

This count may include duplicates, for example where the same enquiry has been made through different channels.

Potential new megawatts
39,375

This is the sum of the capacities of all enquiries for generation, energy storage, load and network upgrades.

“ A runback scheme will allow us to
use more of the
Runback schemes give us more
work!
- Power systems engineers





RURAL TERMINAL STATION

Normal generation



Normal load



Normal power flows through transformers

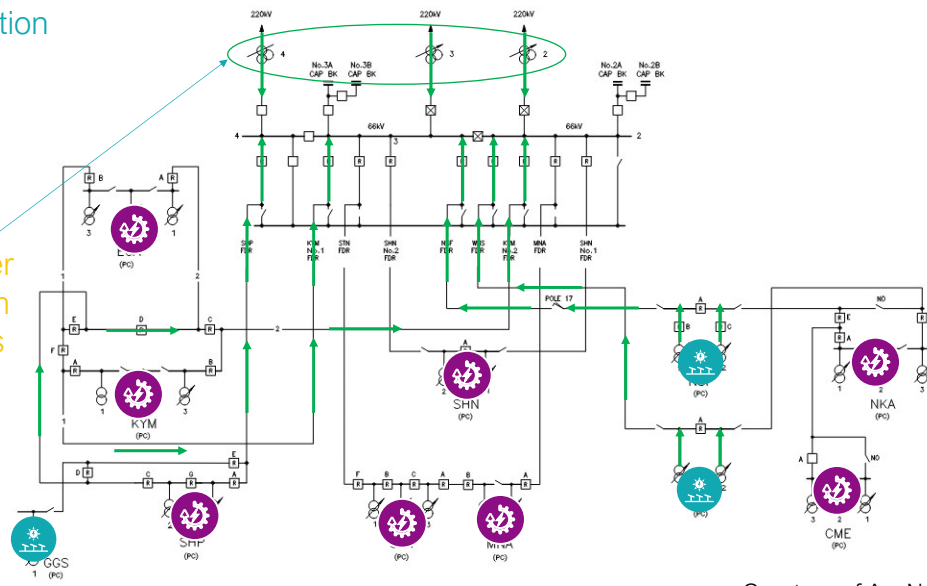

Courtesy of AusNet Services

RUNBACK IN NEW ZEALAND?

- Numerous Transpower special protection schemes
- Several runback schemes
- Some involving distributed generation
- Can look on Transpower's website